

RB-19 REFRIGERATED BARREL

IN-HOUSE CUSTOM GRAPHICS CAPABILITIES



**2 Interior Baskets for
Easy Product Rotation**

- Barrel Design Cooler
- Stimulates Impulse Purchases
- Low Profile Space Efficient
- 2" Casters Included
- Durable Metal Cabinet
- Exterior LED Thermostat Control
- Easy Lift Glass Lid with Handle
- Eco-Friendly R134a Refrigerant
- 2 Coated Interior Wire Baskets For Easy Product Rotation
- 10' Power Cord
- Cools Down to 32°F/0°C

RB-19 REFRIGERATED BARREL COOLER

REFRIGERATED BARREL COOLER

- Barrel Design Cooler
- Stimulates Impulse Purchases
- Low Profile Space Efficient
- Durable Metal Cabinet
- Durable Baked-on Paint Finish
- Factory Engineered Refrigeration System
- Factory Set Thermostat
- Eco Friendly R134a Refrigerant
- Exterior LED Thermostat Control
- Exterior On/Off Switch
- 10' Power Cord
- Easy Lift Glass Lid with Handle
- 2 Coated Interior Wire Baskets (for easy product rotation)
- 2" Casters
- UL Listed 
- Cools Down to 32°F/0°C
- 115V/60HZ
- Custom Graphics Optional

SPECIFICATIONS

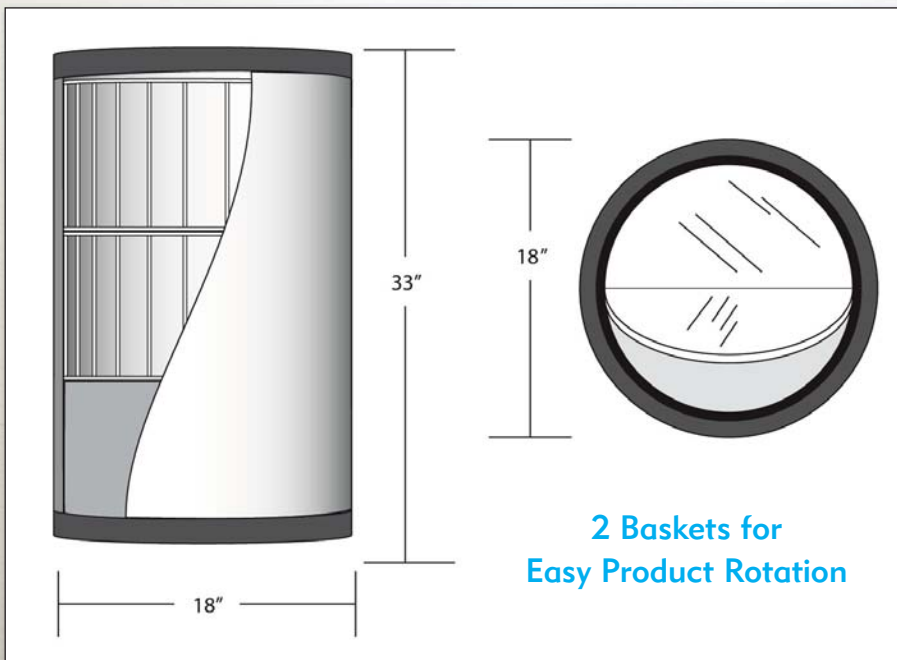

Exterior Dimensions: 18.1"Diam x 33"H
Interior Dimensions: 14.8"Diam x 16.5"H
Package Dimensions:
 21.85"W x 21.85"D x 34.65"H

Net Wt: 47.4 Pounds
Gross Wt: 55.1 Pounds

Units Per 40' Container: 168
Units Per Pallet: 8
Pallets Per 53' Truck: 28
Units Per 53' Truck: 224

PRODUCT CAPACITY

Estimated Product Capacity

- 72 8.3 Ounce Cans
- 42 16 Ounce Cans
- 52 12 Ounce Cans
- 28 24 Ounce Cans

WARRANTY One Year Parts, 90 Days Labor
SPARE PARTS Inventoried